

## **PWB- N550 and PWB-M120 Power Board – Easy Guide for Your Easy Use**

Rev. 1.0

VIA PWB-M120 is the power board designed for the EPIA Mini-ITX series mainboards with either Luke or C7 microprocessor while PWB-N550 is for EPIA Nano-ITX series mainboards to support the function of DC-to-DC.

### ➤ PWB-N550

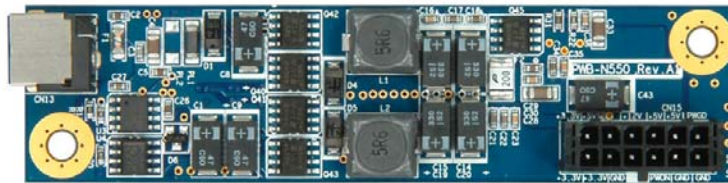

### ➤ PWB-M120



The information contained herein is the exclusive property of VIA and shall not be distributed, reproduced, or disclosed in whole or in part without prior written permission of VIA.

● **Specification**

➤ PWB-N550

<b>DC Input</b>	<b>Input</b>	<b>Minimum</b>	<b>Nominal</b>	<b>Maximum</b>	
	Voltage	11.4V	12V	12.6V	
	Current	5A			
<b>DC Output Voltage</b>	<b>Output</b>	<b>Minimum</b>	<b>Minimum</b>	<b>Maximum</b>	<b>Maximum Combined Power</b>  61.2W
	+5V_SB	4.75V	5V	5.25V	
	+3.3V	3.14V	3.3V	3.47V	
	+5V	4.75V	5V	5.25V	
	+12V	11.4V	12V	12.6V	
	Power Good	4.75V	5V	5.25V	
<b>DC Output Current</b>	<b>+5V_SB</b>	<b>+3.3V</b>	<b>+5V</b>	<b>+12V</b>	<b>Power Good</b>
	0.8A	4A	4A	2A	-
<b>Protection</b>	<ul style="list-style-type: none"> <li>- Input Voltage Protection (Over Voltage Protection)</li> <li>- Output Voltage Protection (Over Voltage Protection) OVP</li> <li>- Output Current Protection (Output Short Protection)</li> <li>- Output Voltage Protection (Under Voltage Protection) UVP</li> </ul>				
<b>Operating Temperature</b>	0 ~ 50 ° C				
<b>Operating Humidity</b>	0% ~ 95% (relative humidity; non-condensing)				
<b>Form Factor</b>	<ul style="list-style-type: none"> <li>- 4 Layers</li> <li>- 10cm x 2.5cm</li> </ul>				

## ➤ PWB-M120

<b>DC Input</b>	<b>Input</b>	<b>Minimum</b>	<b>Nominal</b>	<b>Maximum</b>		
	Voltage	11.4V~22.8V	12V~24V	12.6V~25.2V		
	Current	5.42A~10.84A				
<b>DC Output Voltage</b>	<b>Output</b>	<b>Minimum</b>	<b>Minimum</b>	<b>Maximum</b>	<b>Maximum Combined Power</b>  122.2W	
	+5V_SB	4.75V	5V	5.25V		
	+3.3V	3.14V	3.3V	3.47V		
	+5V	4.75V	5V	5.25V		
	+12V	11.4V	12V	12.6V		
	-12V	-13.2V	-12V	-10.8V		
	Power Good	4.75V	5V	5.25V		
<b>DC Output Current</b>	<b>+5V_SB</b>	<b>+3.3V</b>	<b>+5V</b>	<b>+12V</b>	<b>-12V</b>	<b>Power Good</b>
	2A	6A	6A	5A	200mA	0.1A
<b>Protection</b>	<ul style="list-style-type: none"> <li>- Output Voltage Protection (Over Voltage Protection) OVP</li> <li>- Output Current Protection (Output Short Protection)</li> <li>- Output Voltage Protection (Under Voltage Protection) UVP</li> </ul>					
<b>Operating Temperature</b>	0 ~ 50 °C					
<b>Operating Humidity</b>	0% ~ 95% (relative humidity; non-condensing)					
<b>Form Factor</b>	<ul style="list-style-type: none"> <li>- 4 Layers</li> <li>- 15cm x 5.1cm</li> </ul>					

● **Layout Diagram & Mounting Holes**

➤ PWB-N550

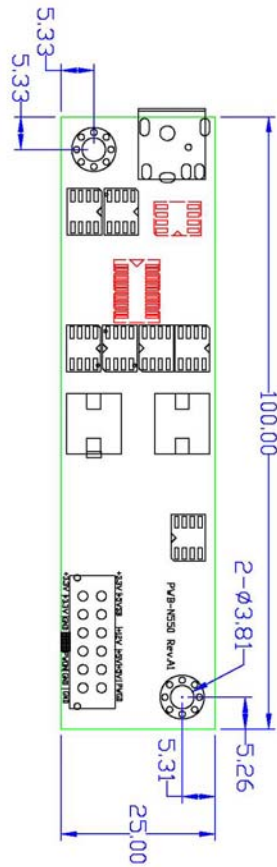
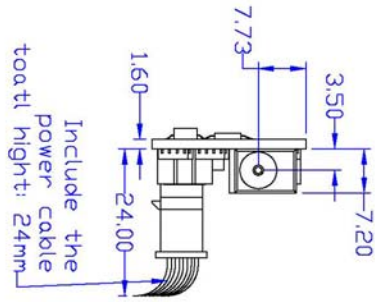

➤ PWB-M120 (MAINBOARD)

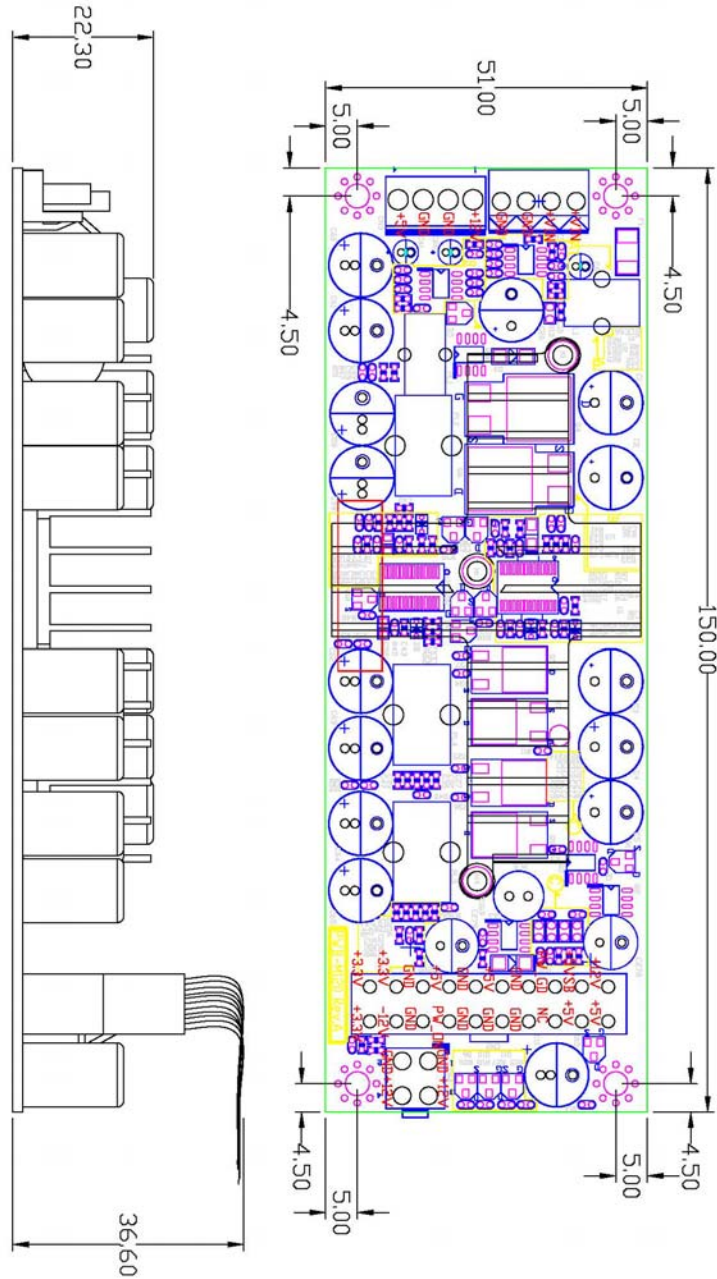

➤ PWB-M120 (DC\_IN MODULE)

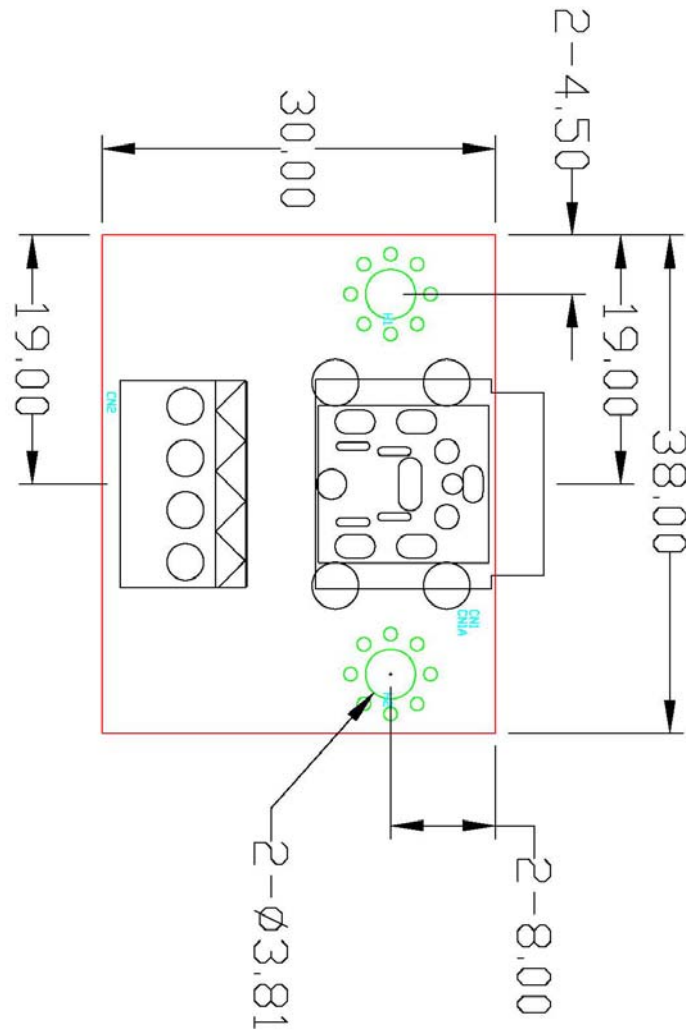

- **Assembly instructions**

- PWB-N550

- ⊕ In the power board package, you will find:

- (1) Power board x 1
    - (2) 6 x 2-pin power cable with IDE/FDD connectors x 1

1. As you can see the screw-fixing holes indicated in the red circles below, hold the power board in the right position of case, Then, fix the screws to the holes.

2. Fix the power cable to the right connectors as follows





(1) CN13

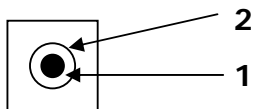

Pin	Signal
1	Vin (anode) +12V $\varnothing=2.5\text{mm}$
2	GND

(2) CN15

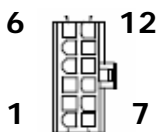

Pin	Signal
1	+3.3V (Output Voltage)
2	+5VSB (5V ONLY)
3	+12V (Output Voltage)
4	+5V (Output Voltage)
5	+5V (Output Voltage)
6	Power Good (PGD 5V )
7	+3.3V (Output Voltage)
8	+3.3V (Output Voltage)
9	GND
10	P_ON ( Power On )
11	GND
12	GND

VIA CONFIDENTIAL

➤ PWB-M120

⊕ In the power board package, you will find:

- (1) Power board x 1
- (2) DC\_IN module x 1
- (3) DC input power cable x 1
- (4) 10 x 2-pin power cable x 1
- (5) IDE/FDD power cable x 1

1. As you can see the screw-fixing holes indicated in the red circles below, hold the power board in the right position of case, Then, fix the screws to the holes.

2. Fix the power cable to the right connectors as follows

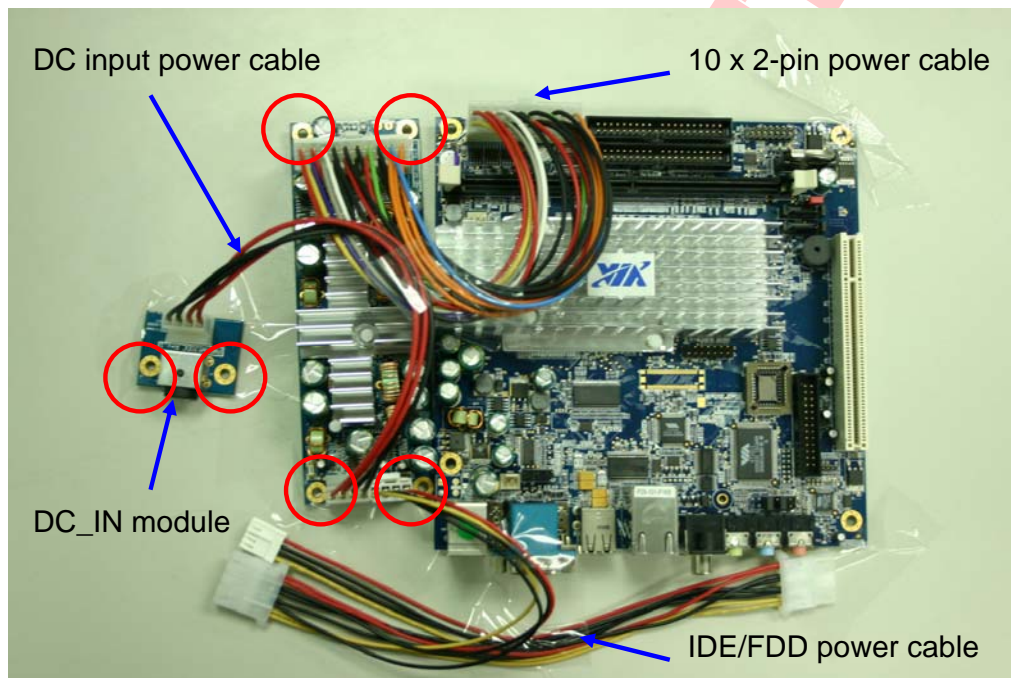

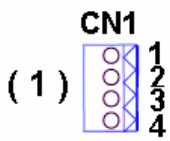
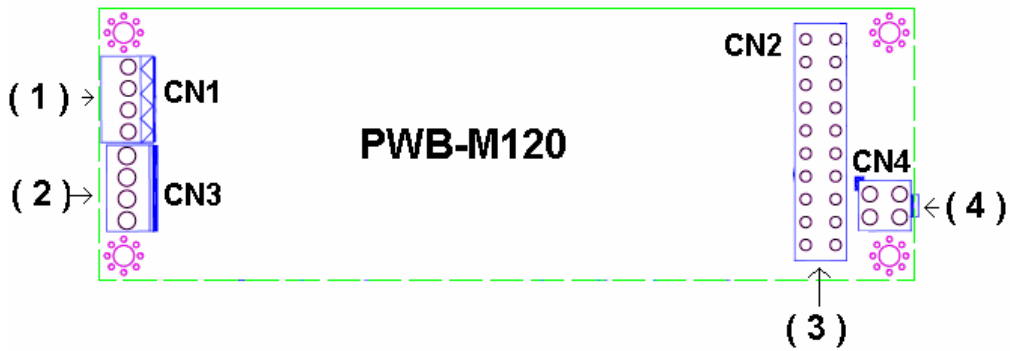

Pin	Signal
1	Vin+ (anode) 12V~24V
2	Vin+ (anode) 12V~24V
3	Vin- (GND)
4	Vin- (GND)

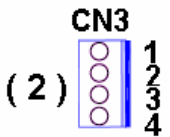

Pin	Signal
1	+12V (Output Voltage)
2	GND
3	GND
4	+5V (Output Voltage)

VIA CONFIDENTIAL

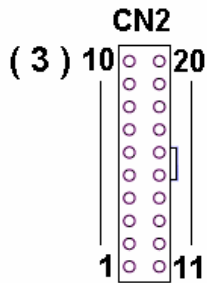

Pin	Signal
1	+3.3V (Output Voltage)
2	+3.3V (Output Voltage)
3	GND
4	+5V (Output Voltage)
5	GND
6	+5V (Output Voltage)
7	GND
8	Power Good (PGD 5V)
9	+5VSB (5V ONLY)
10	+12V (Output Voltage)
11	+3.3V (Output Voltage)
12	NC
13	GND
14	P_ON (Power On)
15	GND
16	GND
17	GND
18	-12V (Output Voltage)
19	+5V (Output Voltage)
20	+5V (Output Voltage)

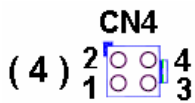

Pin	Signal
1	GND
2	GND
3	+12V (Output Voltage)
4	+12V (Output Voltage)